

A222

MONTAGEANLEITUNG / ASSEMBLY INSTRUCTION

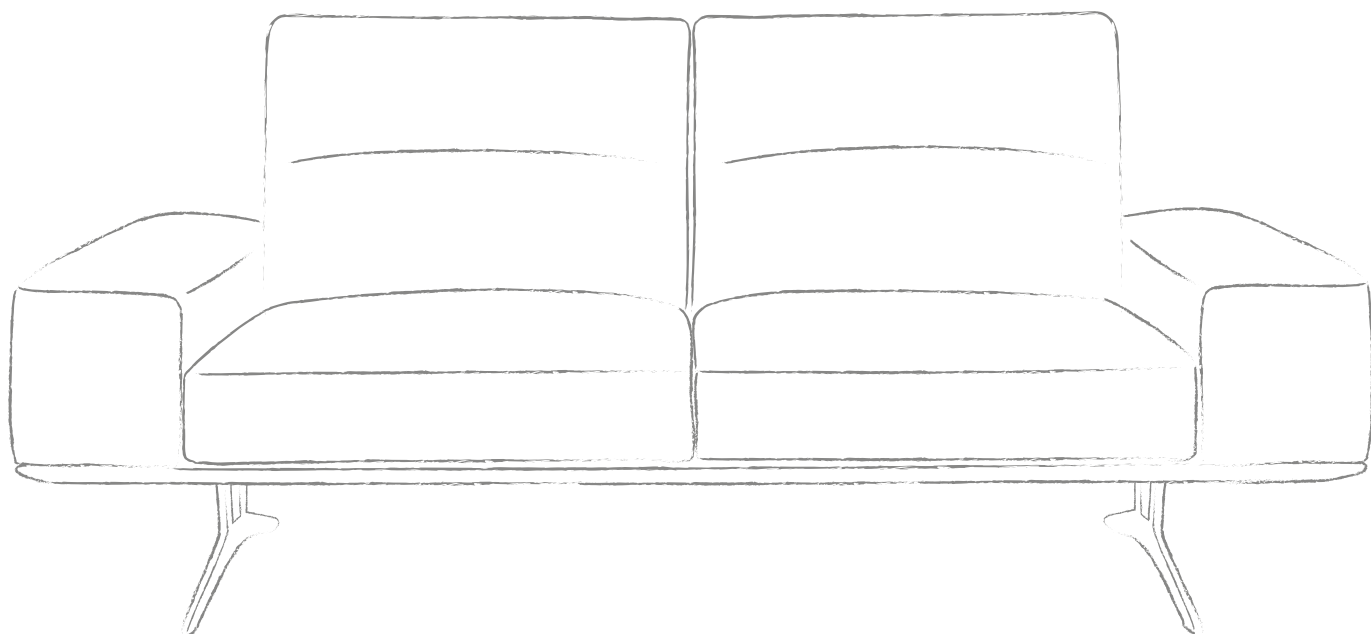

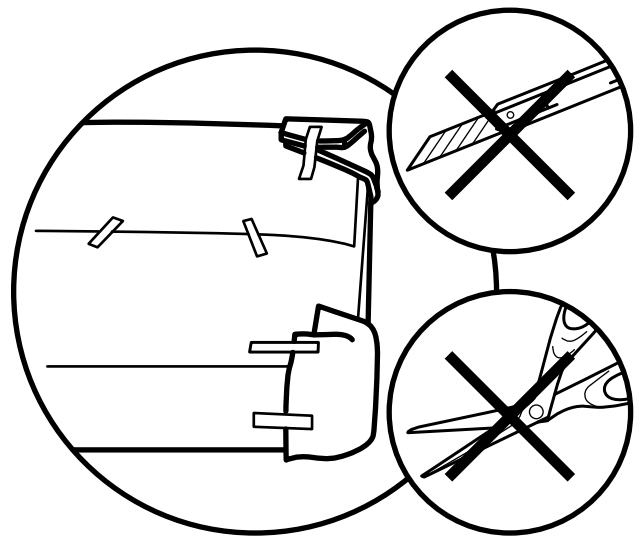
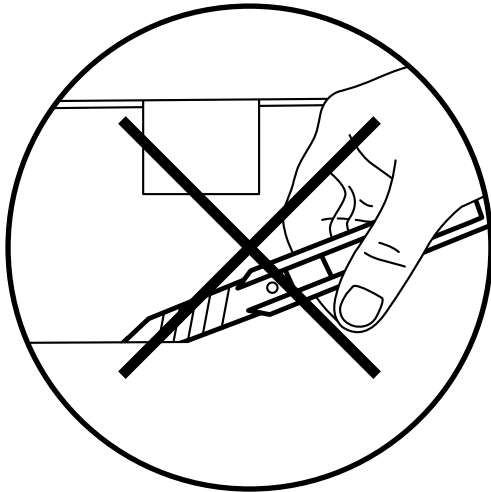
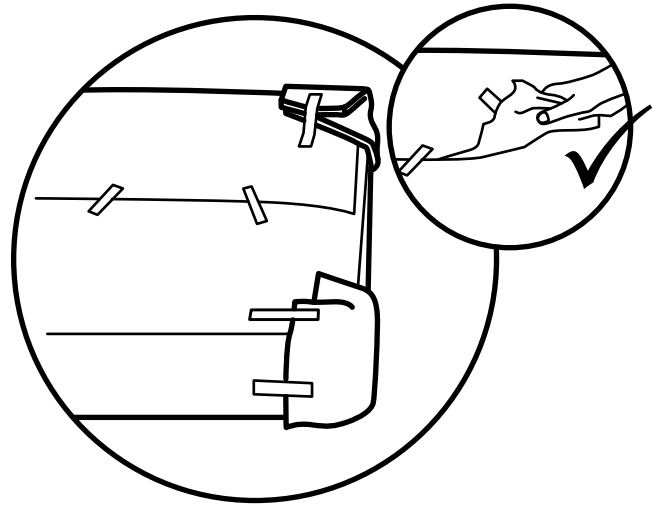
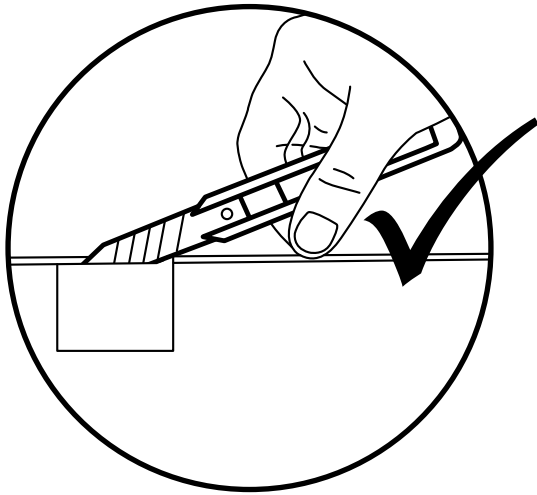

! Hinweis / Note:

Für den Aufbau werden zwei Monteure benötigt. Somit vermeiden Sie vorsorglich Beschädigungen.

Two persons are needed for the assembly. This prevents damage in advance.

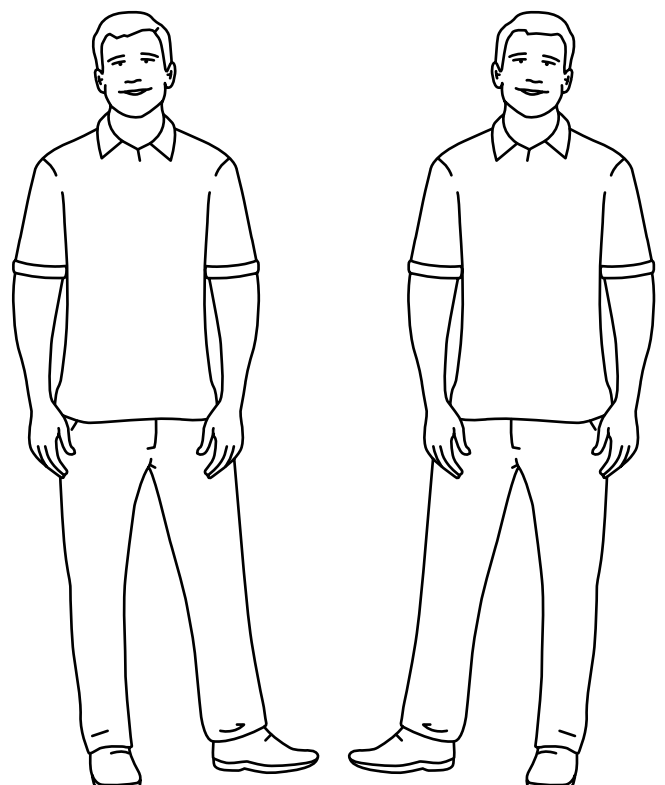

Enhaltenes Montagmaterial / Included mounting material



Gewindestift **8x60 mm**
Setscrew **8x60 mm**

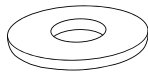

U-Scheibe
Plain washer

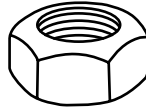

Mutter **M8**
Nuts **M8**



Schutzkappe
Protection Cover

Zusätzliches Montagmaterial / Additional mounting material

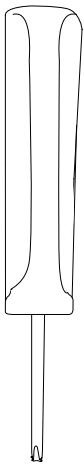

Schraubenschlüssel **M8**
Screw Wrench **M8**

Die Armunterseite muss nach oben zeigen. Schrauben Sie zunächst die mitgelieferten Gewindestifte mit dem langen Ende in die offenen Bohrungen bei den Armteilen ein.

*The arm and back bottom have to show upwards.
Screw the setscrews with the longer end in the provided holes at the armrest or back.*



Die Armteile sind jeweils mit „L“ bzw. „R“ markiert. Dies bezeichnet, ob das Armteil vorstehend auf der linken oder auf der rechten Seite eingesteckt werden muss. Außerdem muss die Naht immer nach außen zeigen.

Each armrest is marked with „L“ or „R“. This shows whether the armrest has to be insert on the left or on the right side (standing in front of the sofa). In addition the seam always have to be place at the outside.



Führen Sie nun die Gewindestifte in die dafür vorgesehenen Öffnungen auf dem Möbelkorpus ein.

Now insert the setscrew in the provided holes at the furniture body.

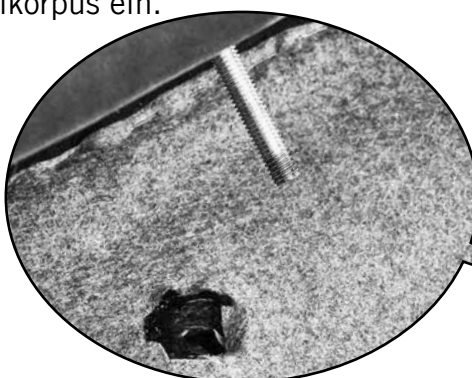

Ist das Armteil bzw. der Rücken eingesteckt, sind die Gewindestifte an der Unterseite des Sofas sichtbar. Legen Sie erst eine Unterlegscheibe um den Gewindestift und schrauben Sie dann die Mutter darüber fest.

If the armrest or the back is inserted, the setscrews are visible at the sofa base. Place one shim to the setscrew and screw a nut above it. Than fix the nut with the screw-wrench.



Stülpen Sie die Schutzkappe über die Mutter. Die Montage ist abgeschlossen.

Place the protection cover over the nut. The assembly is completed.

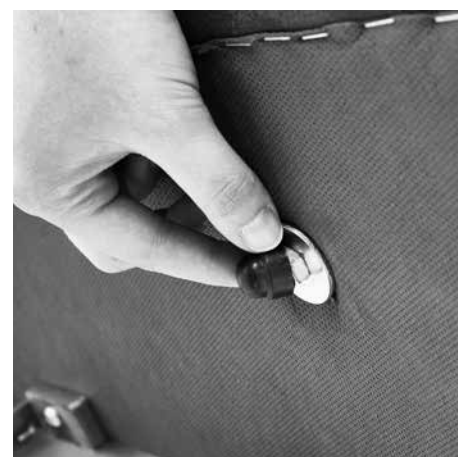

A135

MONTAGEANLEITUNG / ASSEMBLY INSTRUCTION



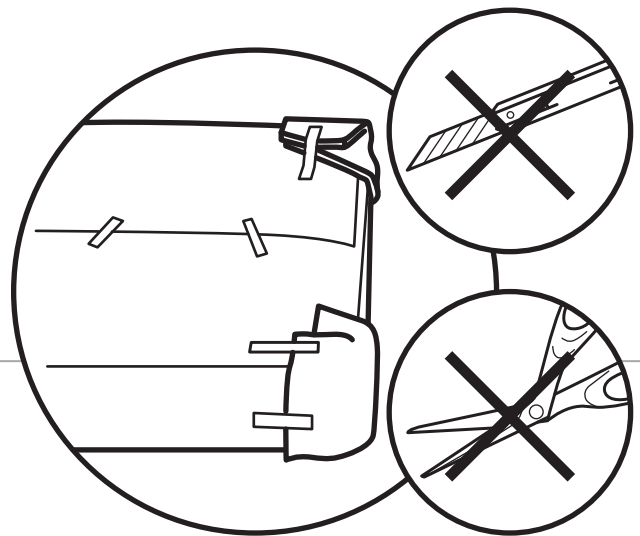
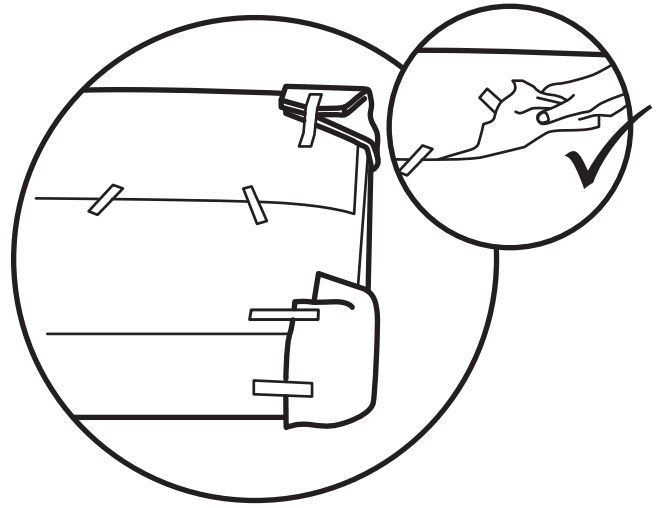
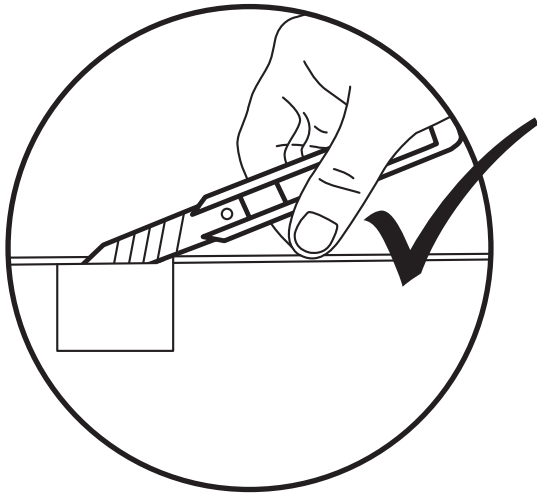

! Hinweis / Note:

Für den Aufbau werden zwei Monteure benötigt. Somit vermeiden Sie vorsorglich Beschädigungen.

Two persons are needed for the assembly. This prevents damage in advance.

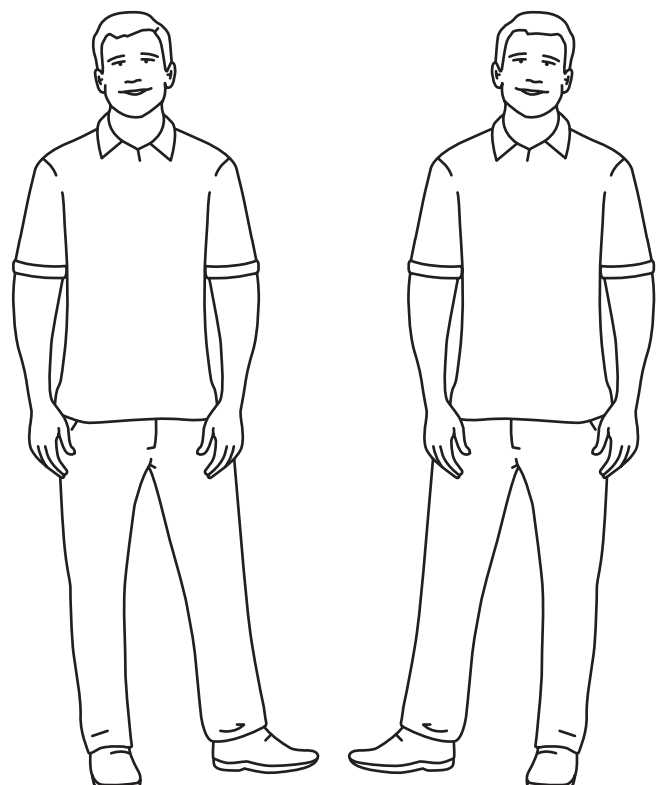

1 Montage Rücken / Assembly back

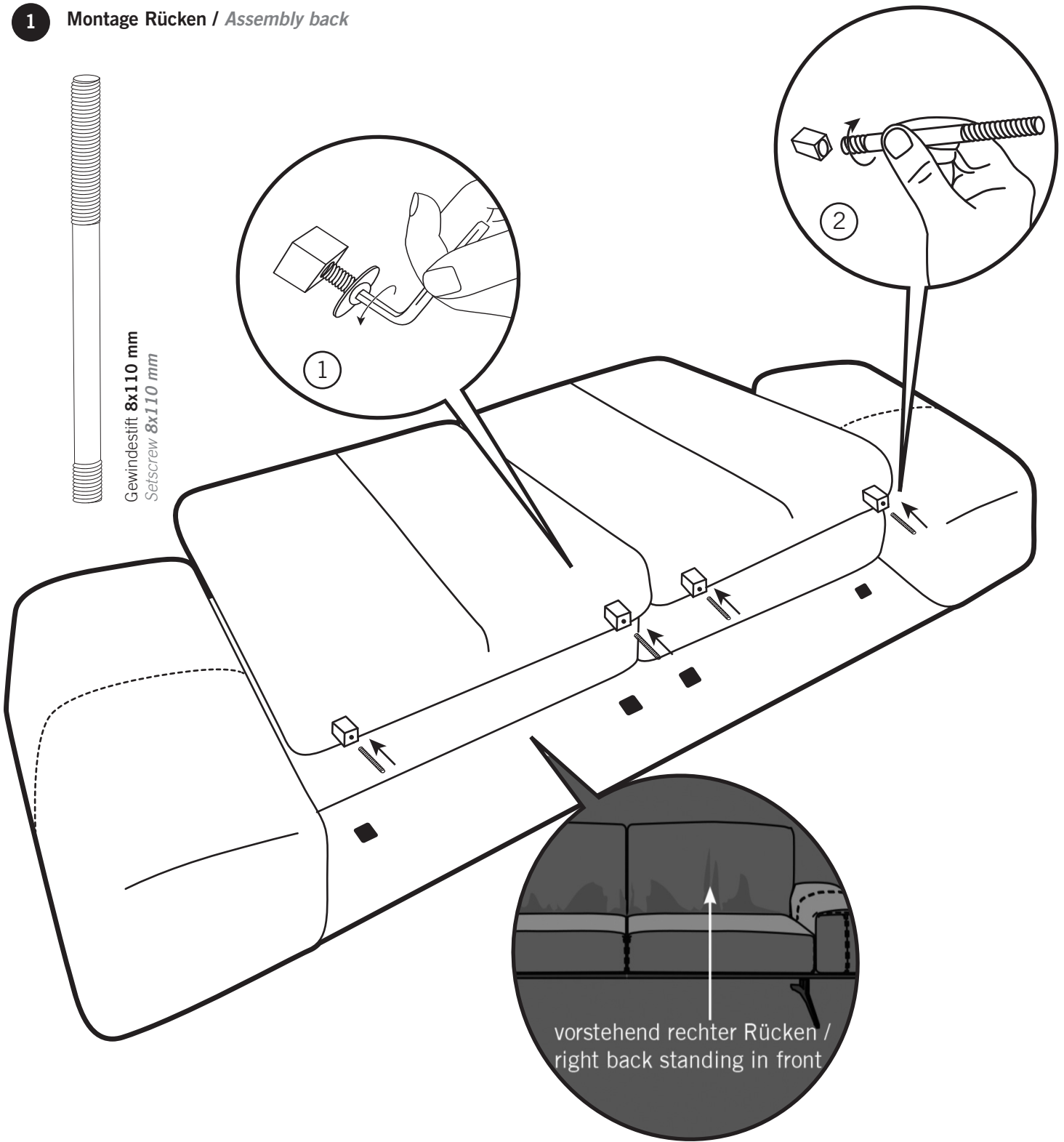

2

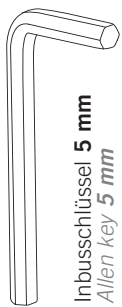

Inbusschlüssel 5 mm
Allen key 5 mm

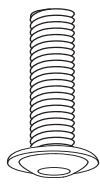

Flanschkopfschraube 8x30 mm
Flange head screw 8x30 mm

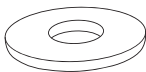

U-Scheibe 10,5 mm
Plain washer 10,5 mm

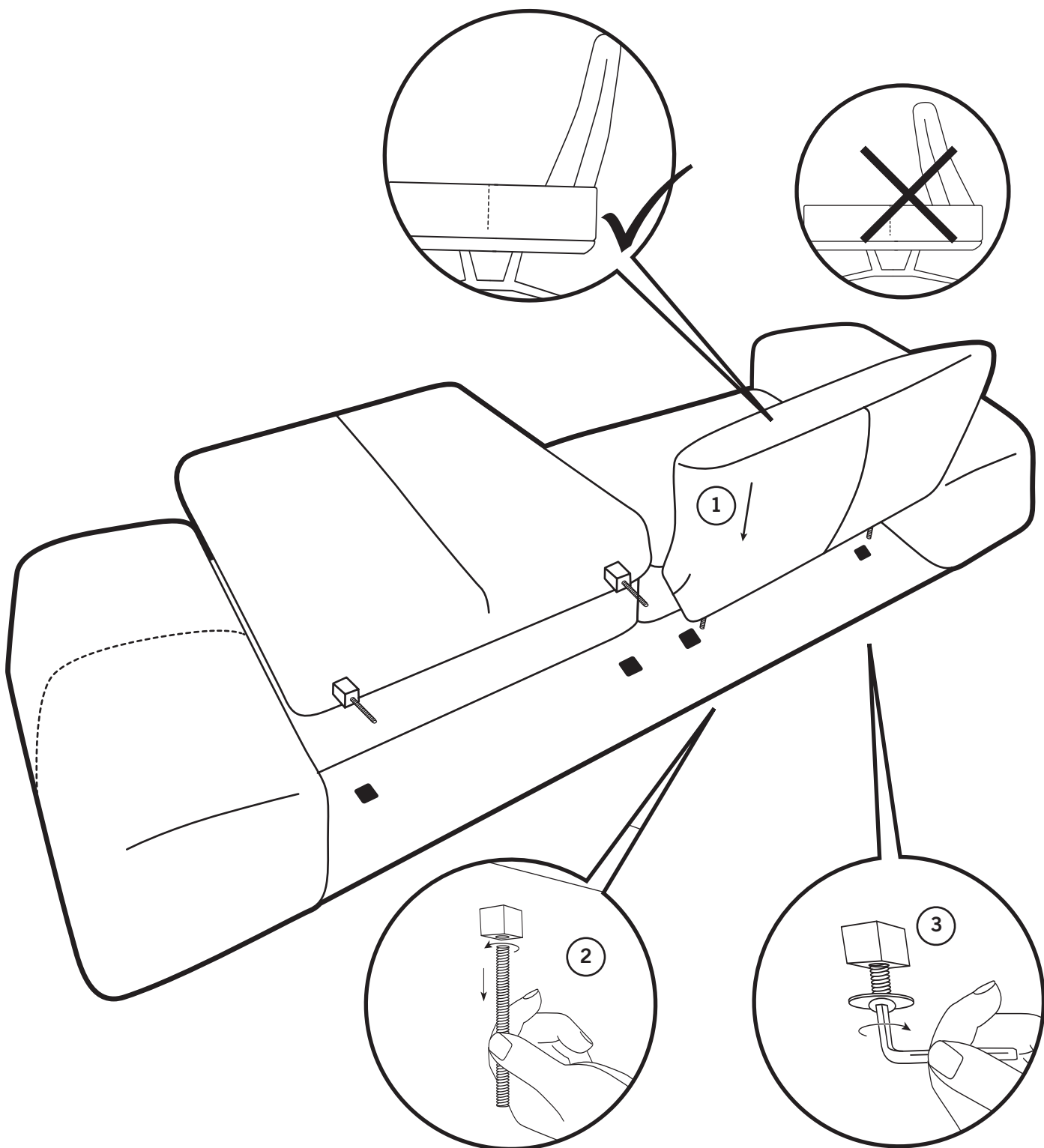



03/2023 Fatlo, Formia, Francis, Fynal, Hiero, Maxwell, Nanci, Volino

A134

MONTAGEANLEITUNG / ASSEMBLY INSTRUCTION

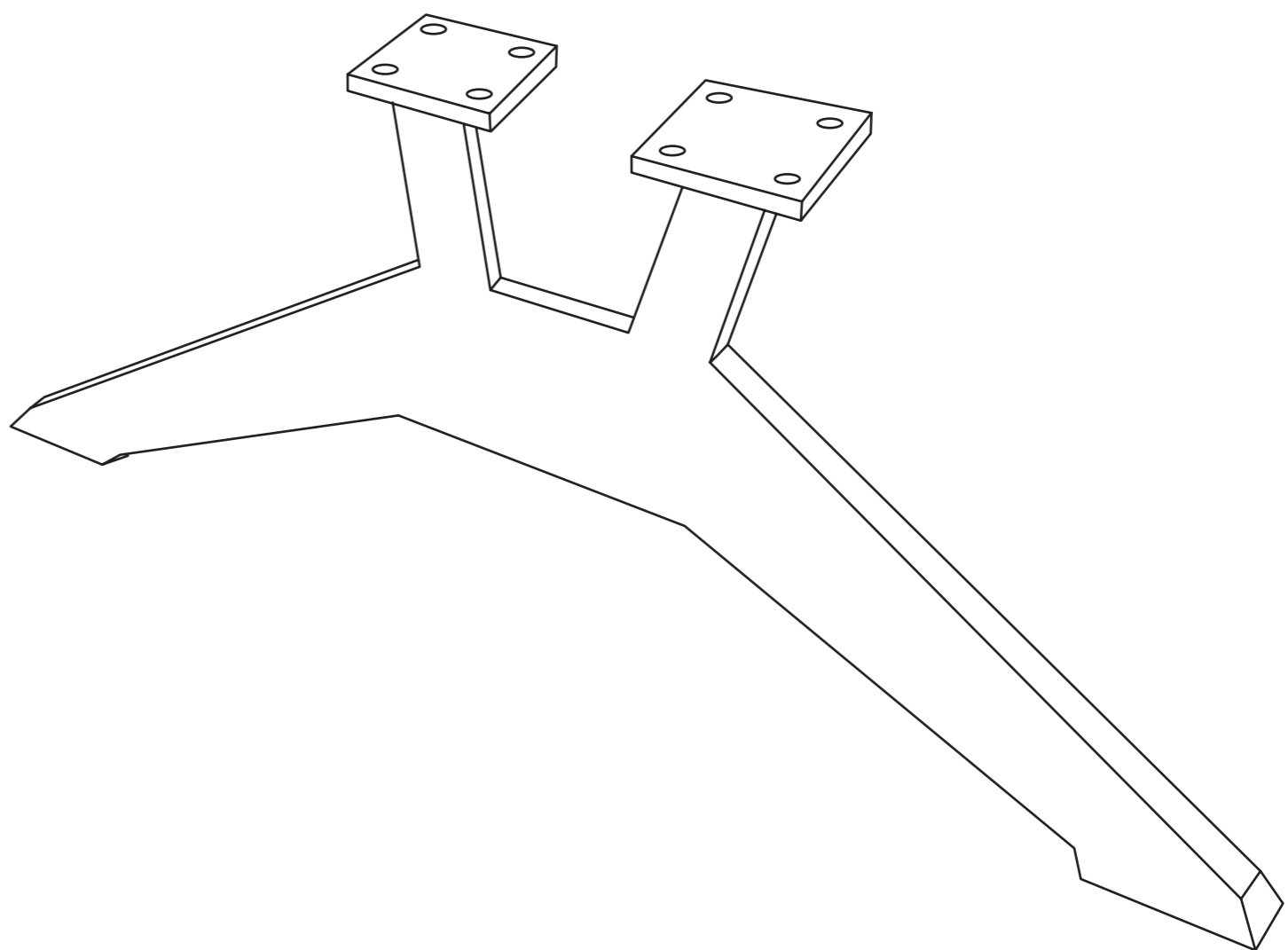

WEEE-Reg.-Nr. DE 69718127



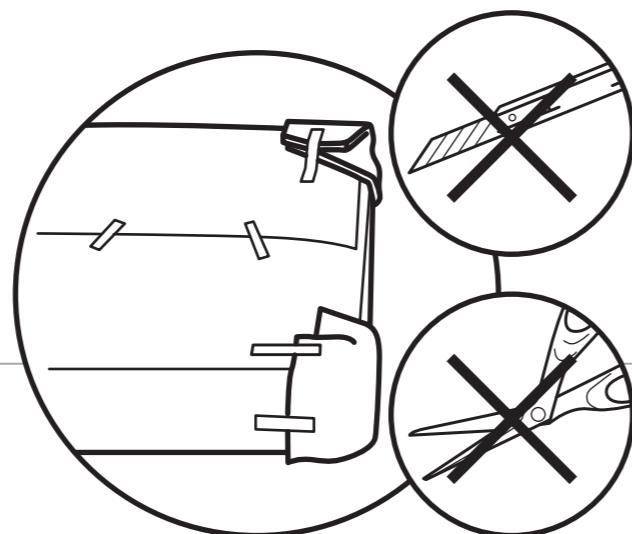
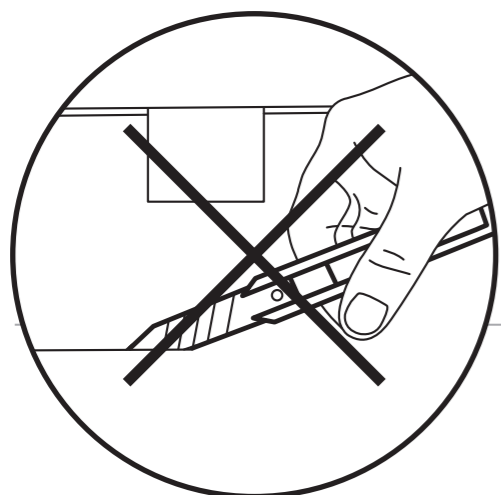
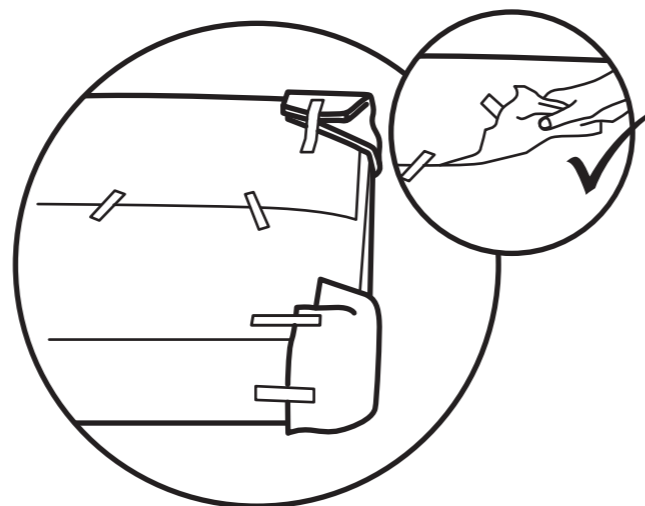
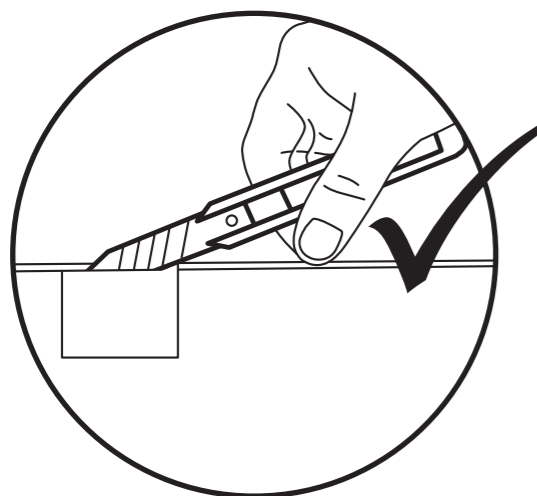

! Hinweis / Note:

Für den Aufbau werden zwei Monteure benötigt. Somit vermeiden Sie vorsorglich Beschädigungen.

Two persons are needed for the assembly. This prevents damage in advance.

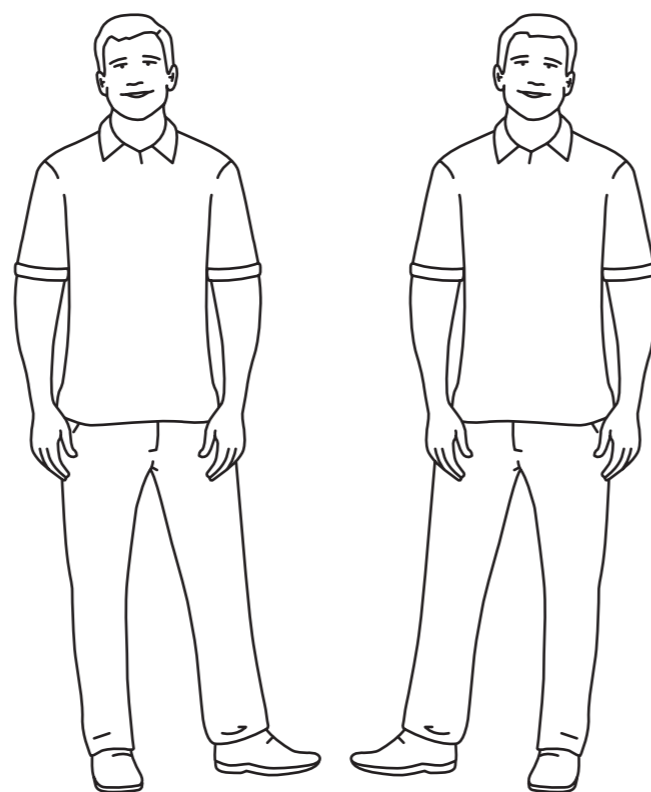

1 Vorbereitung Montage Füße / Preparation assembly feet

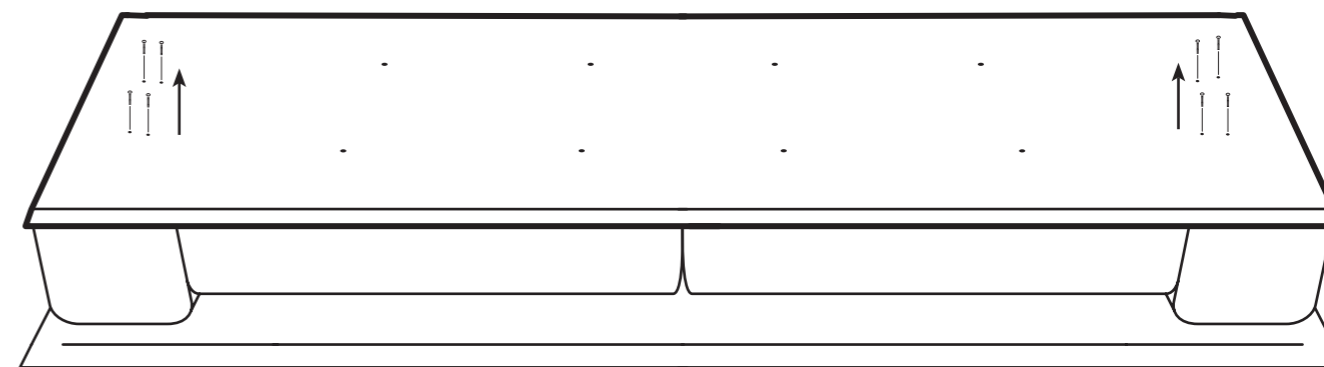

2 Montage Füße / Assembly feet



Inbusschlüssel 4 mm
Allen key 4 mm

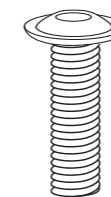

Flanschkopfschraube 6x35 mm
Flange head screw 6x35 mm

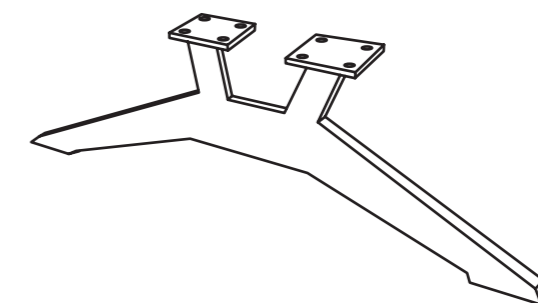

Schwertkufe 750x230 mm
Sword skid 750x230 mm

