

# Möbel LETZ

*Finden und Wohlfühlen*



## Typenplan

Teratai von Bretz - Sofa eisgrau

### **Wichtiger Hinweis für Sie**

Etwaige Hinweise des Herstellers in dieser Produktinformation, die sich auf die Gewährleistung beziehen, haben für Sie keinerlei Bindungswirkung und können von Ihnen ignoriert werden. Ihre gesetzlichen Gewährleistungsrechte als Verbraucher uns gegenüber, als Ihrem Verkäufer, werden dadurch in keiner Weise berührt oder eingeschränkt. Sie können sich wegen aller Mängel jederzeit an uns wenden. Darüber hinaus gehende Herstellergarantien bleiben

Gensingen, Deutschland

Möbel Letz GmbH  
Am Gewerbepark 11  
06895 Zahna-Elster

Tel.: 035383 - 6018 50

Fax.: 035383 - 6018 17

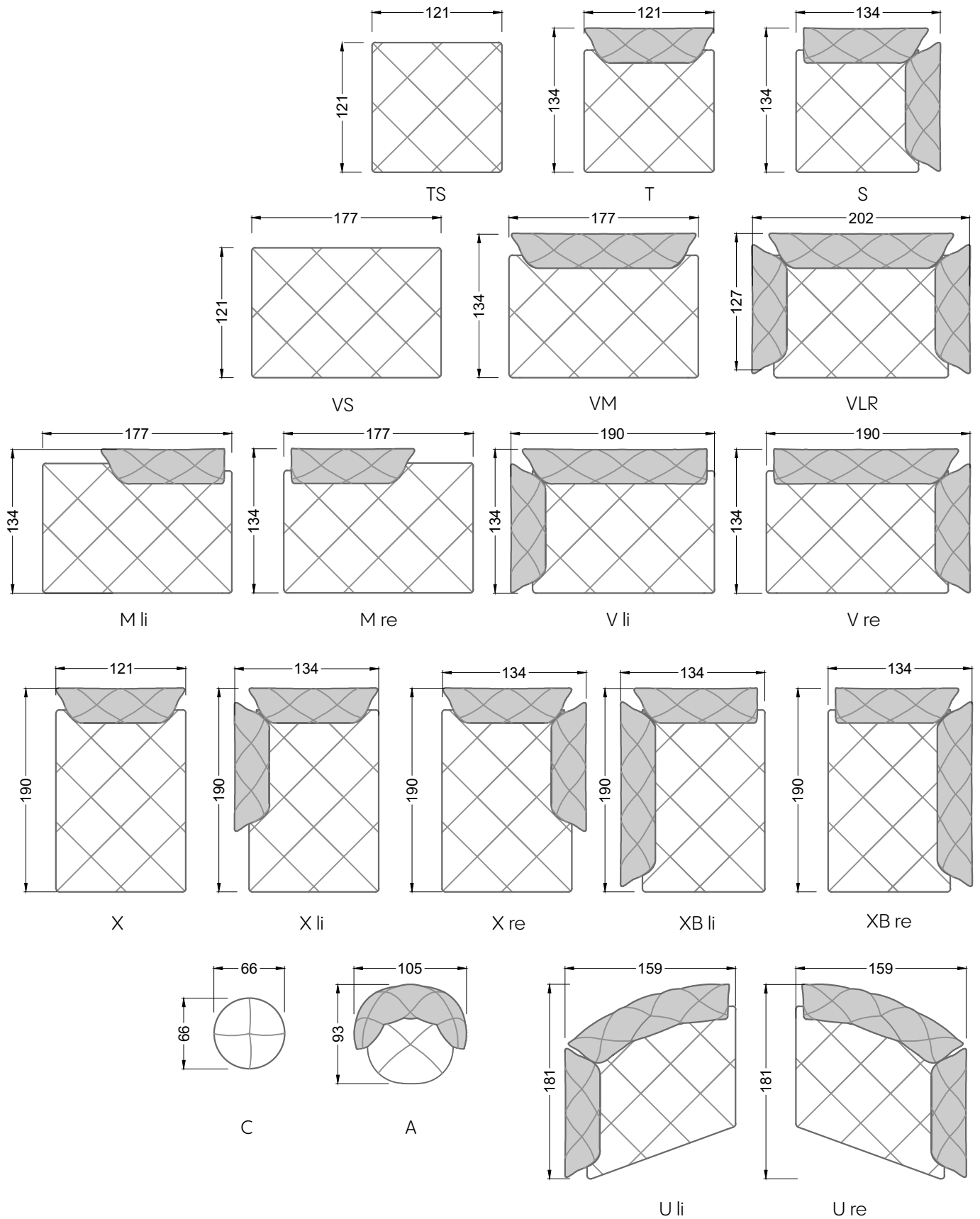

Die Maße gelten für freistehende Einzelteile.

Die Anbauteile weisen an den Anstellseiten eine unecht bezogene Anstellseite ohne Rundung auf.

Die Abschluss- und Einzelteile weisen an den freien Seiten eine Rundung auf (6 cm).

D.h. Bei freier Kombination aus Einzelteilen müssen jeweils 6 cm an den Anstellseiten abgezogen werden.

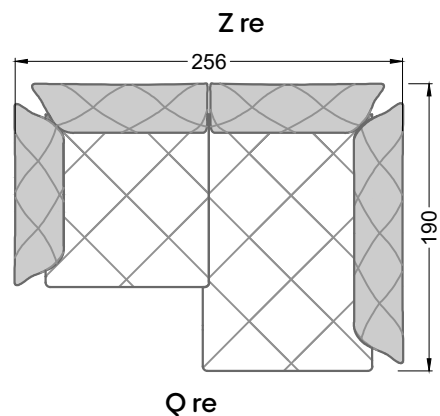
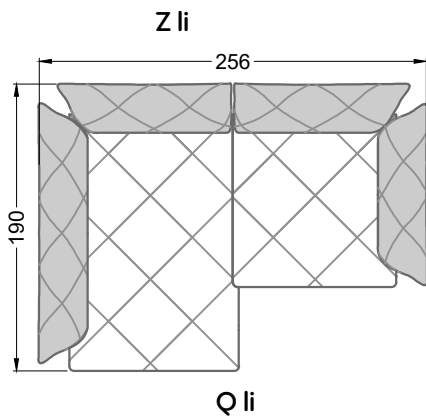
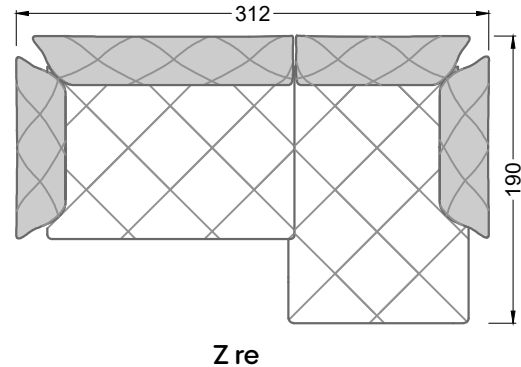
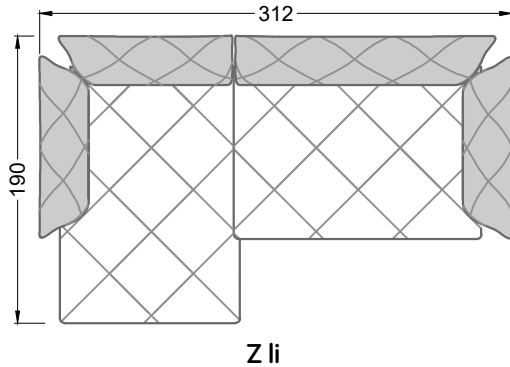
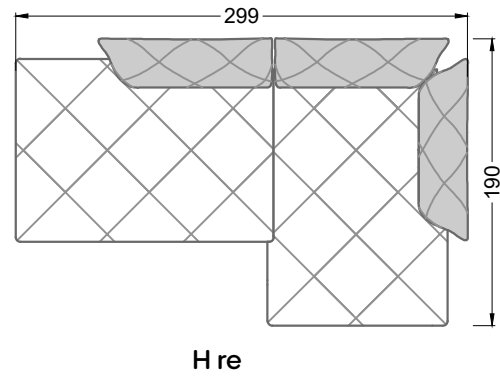
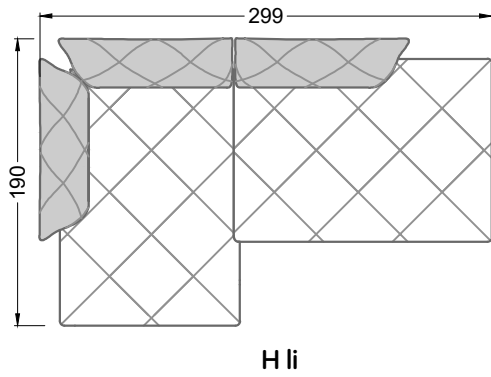
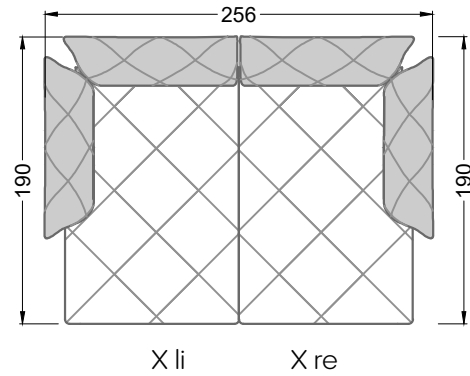
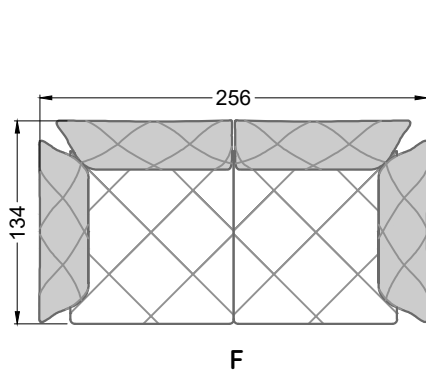
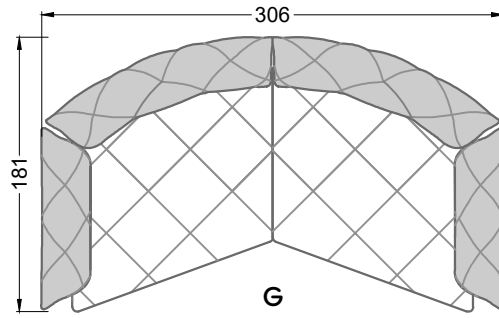

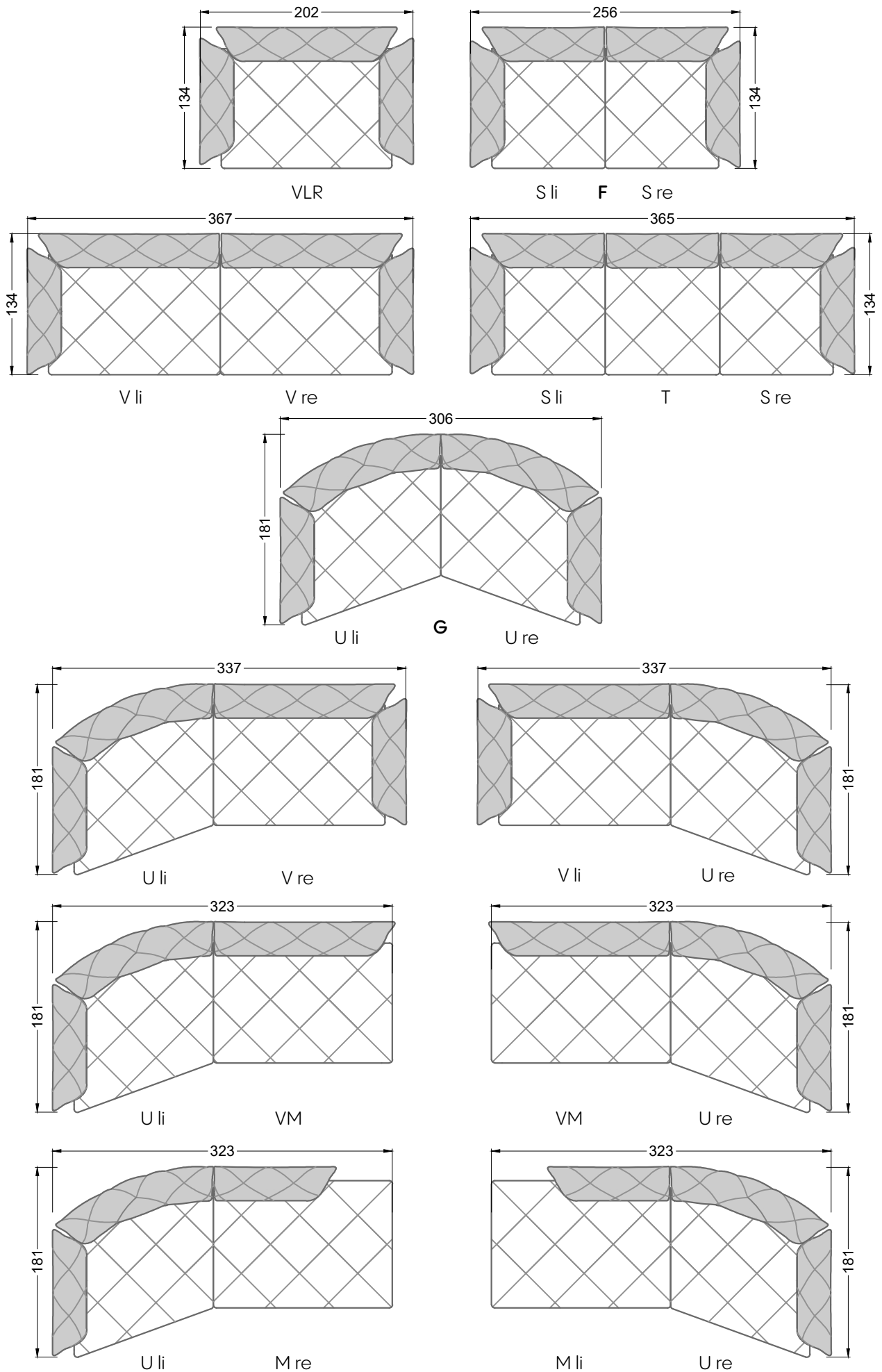

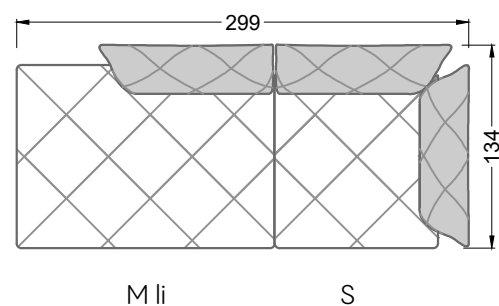
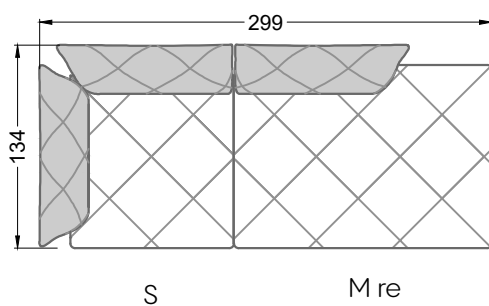
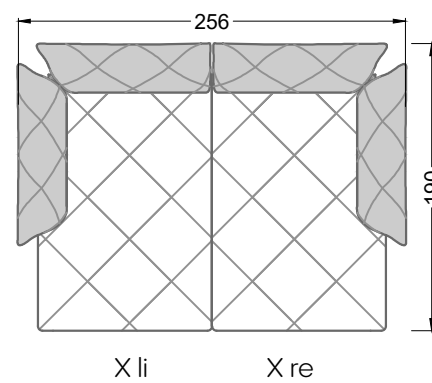
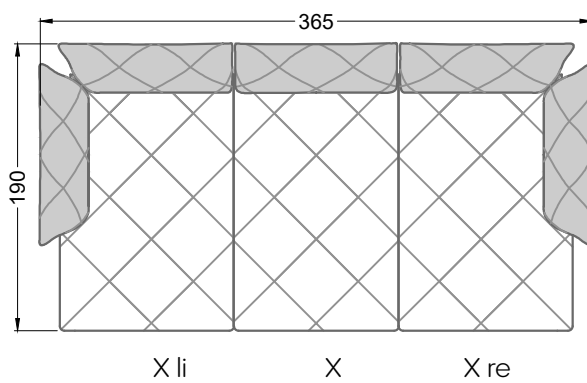
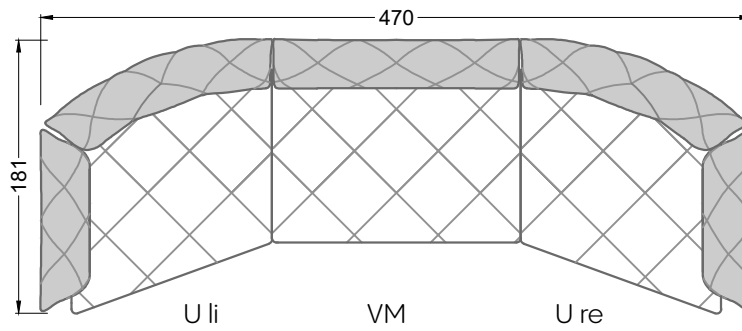
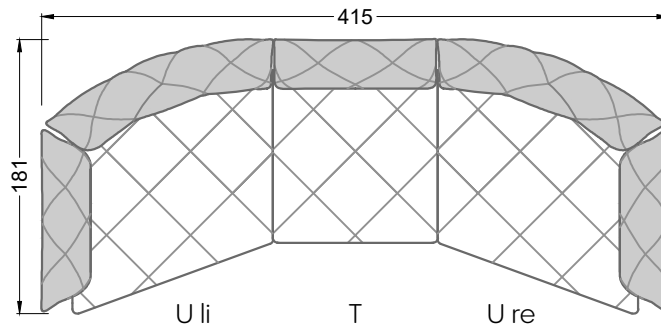
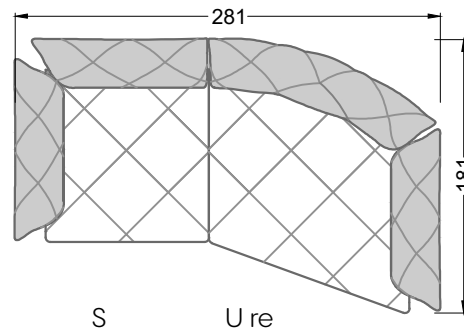
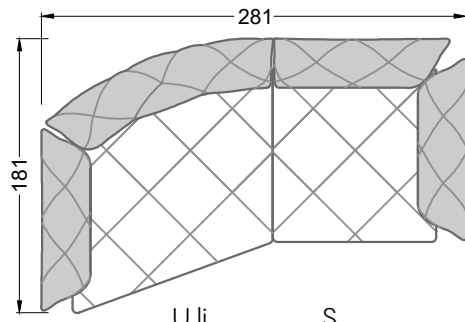

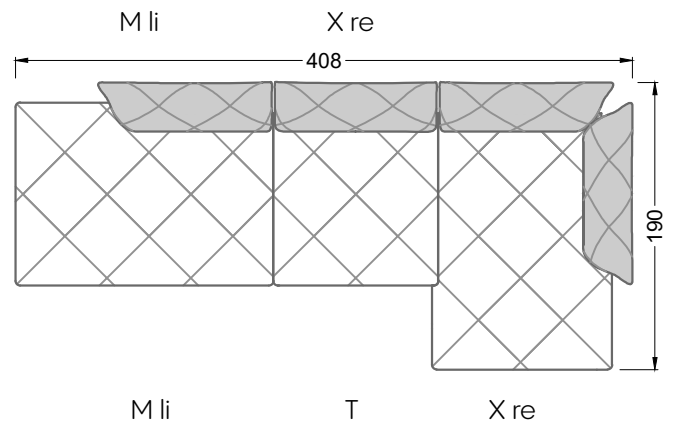
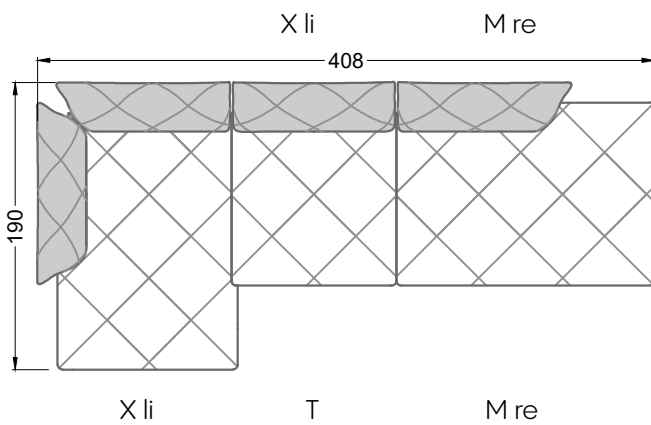
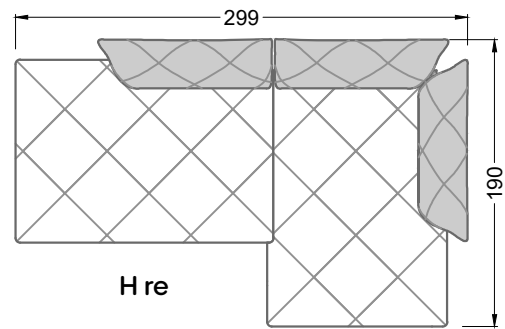
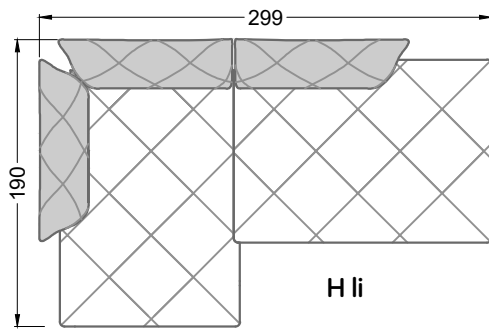
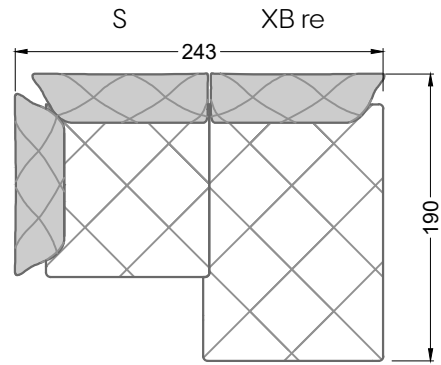
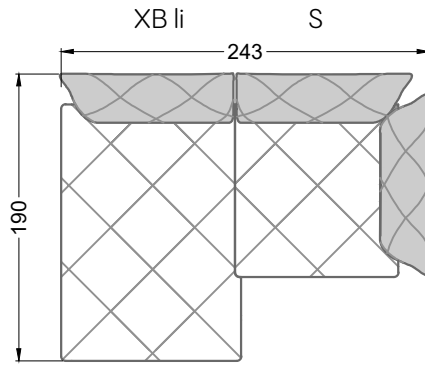
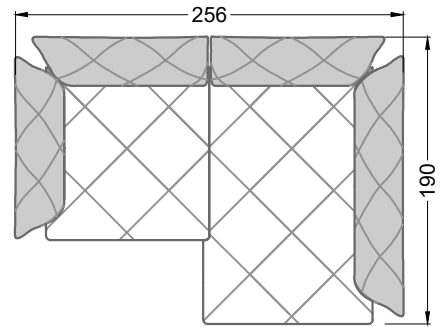
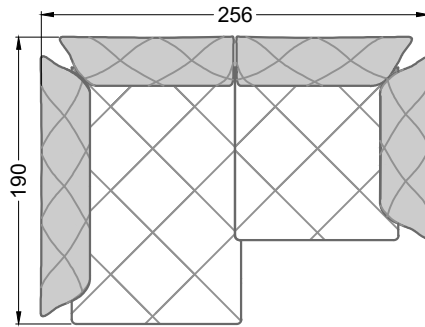
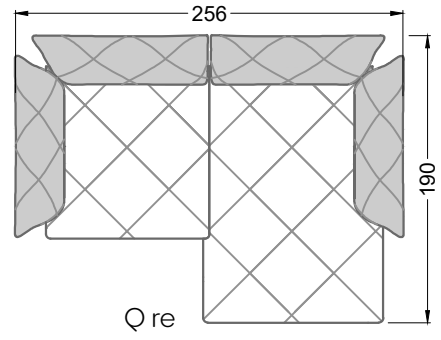
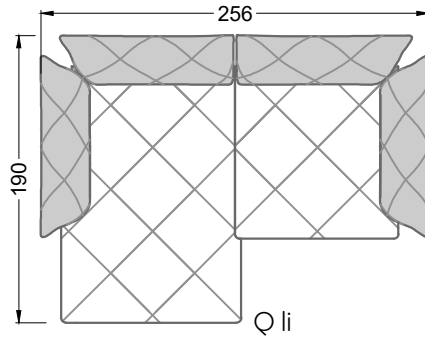

X li T M re

M li T X re

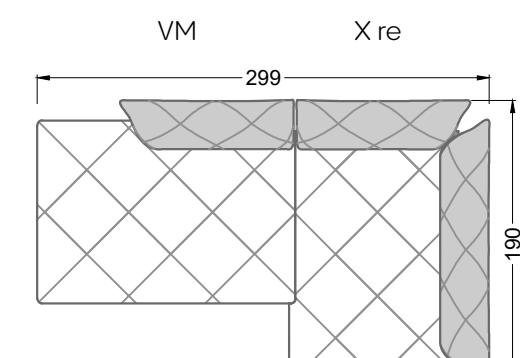
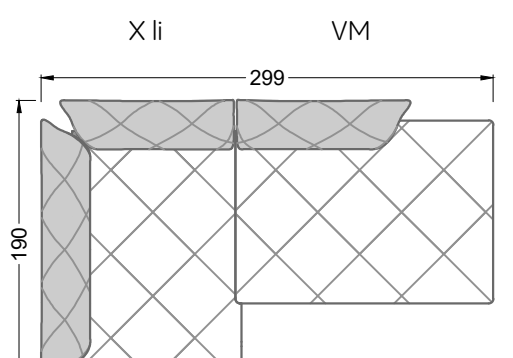
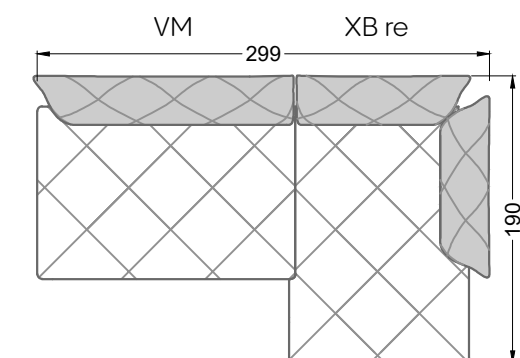
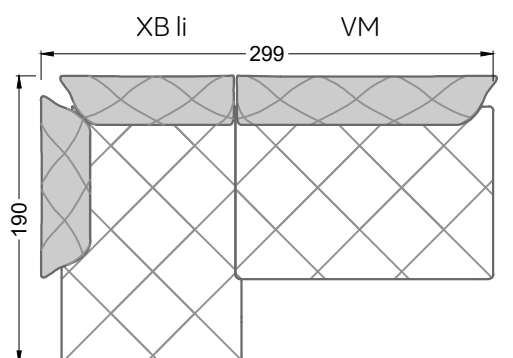
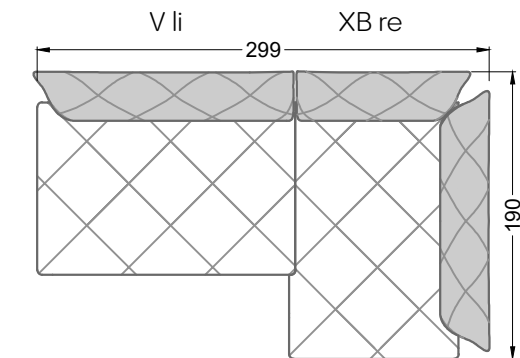
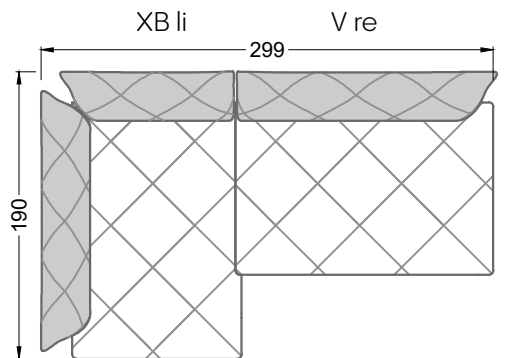
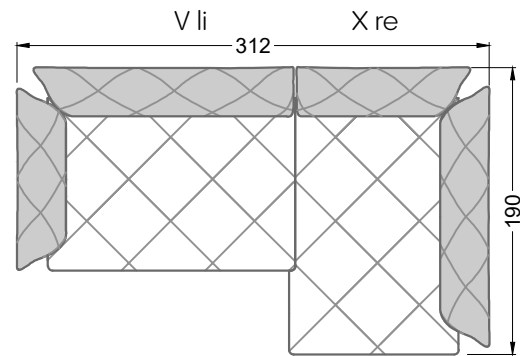
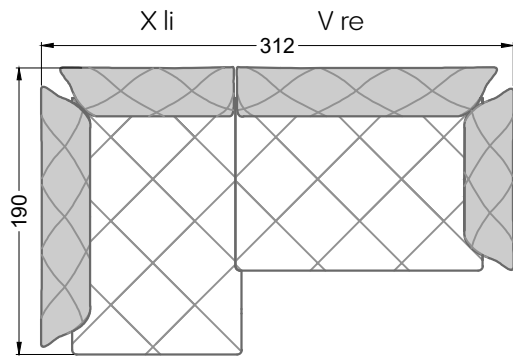
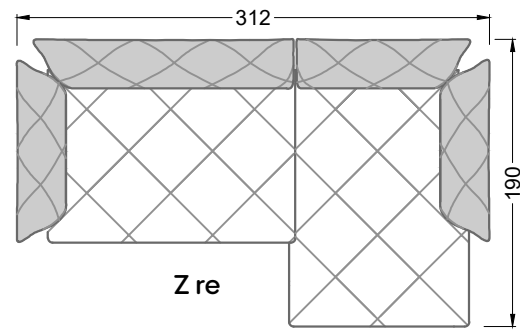
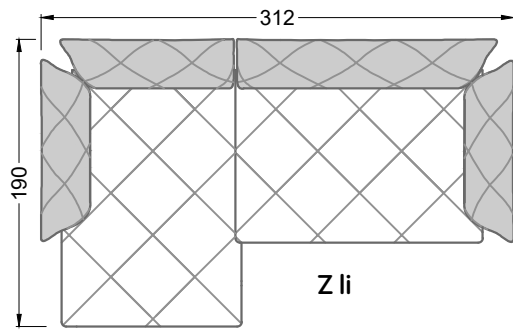

XB li

M li

M li

XB re

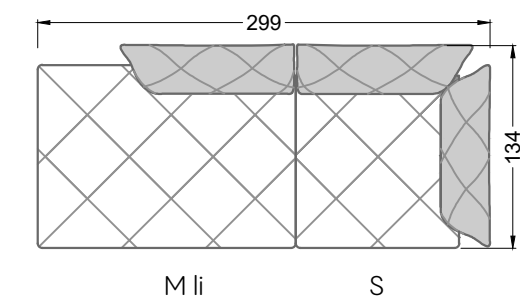
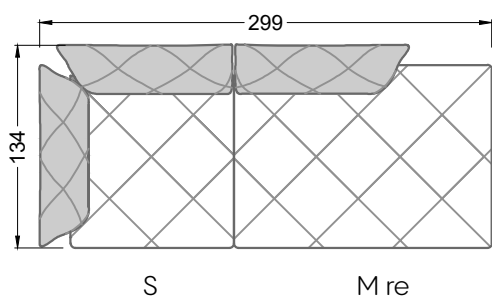
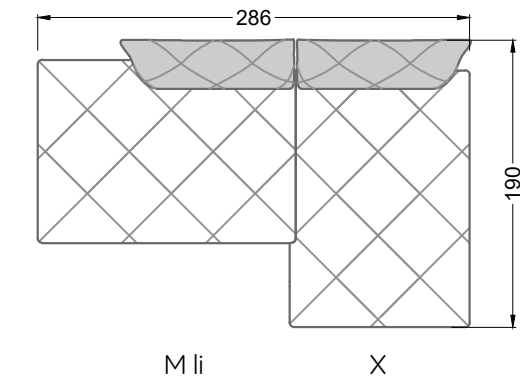
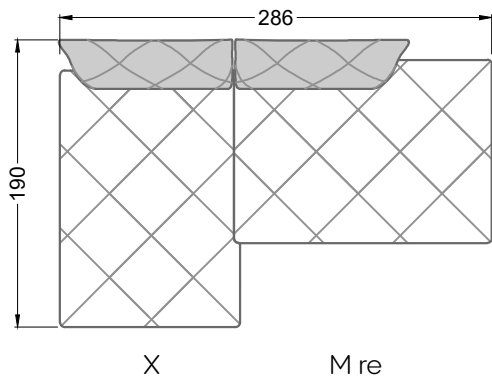
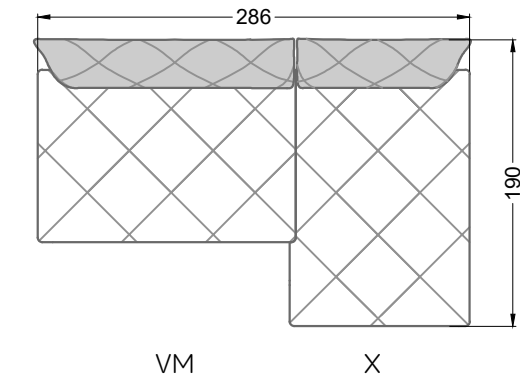
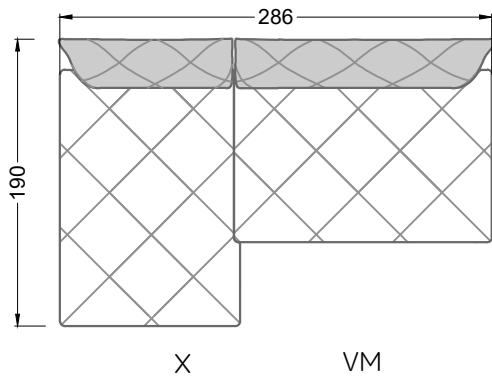
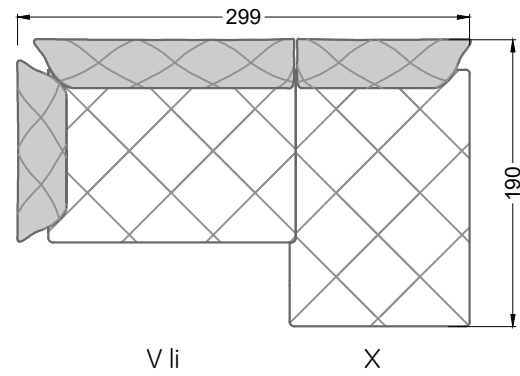
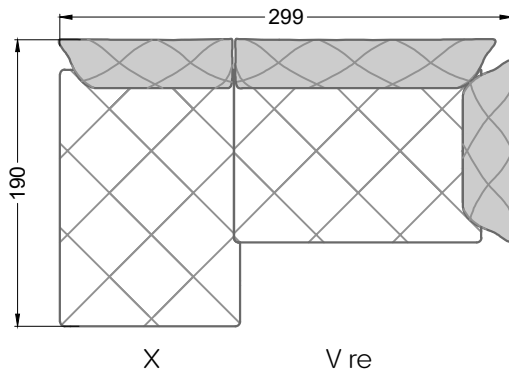
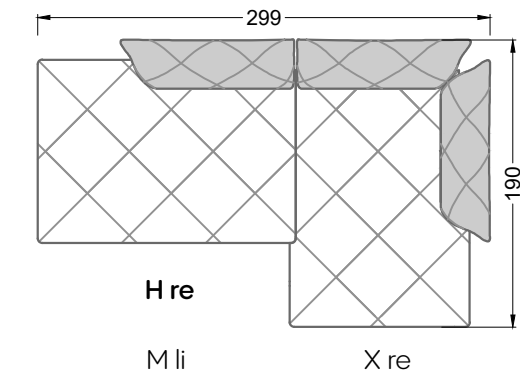
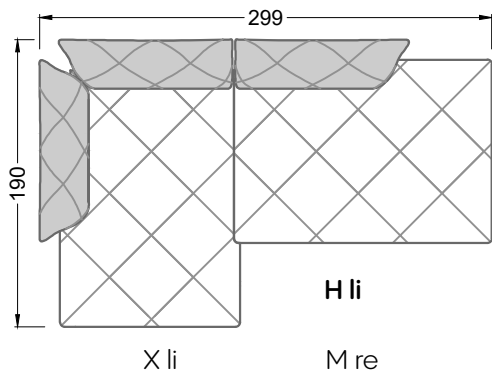

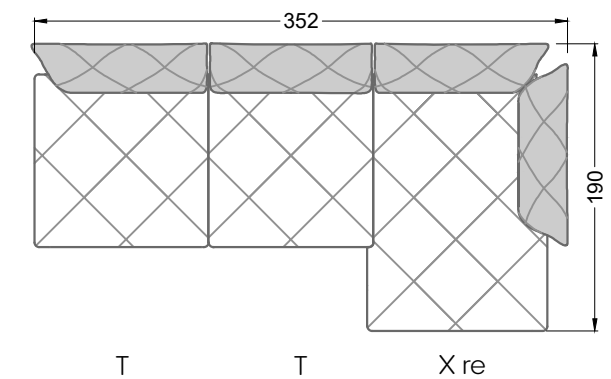
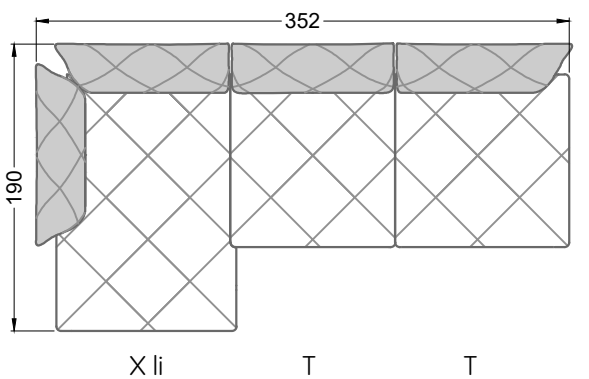
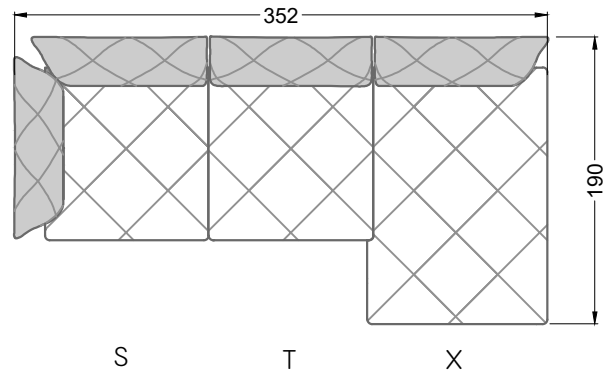
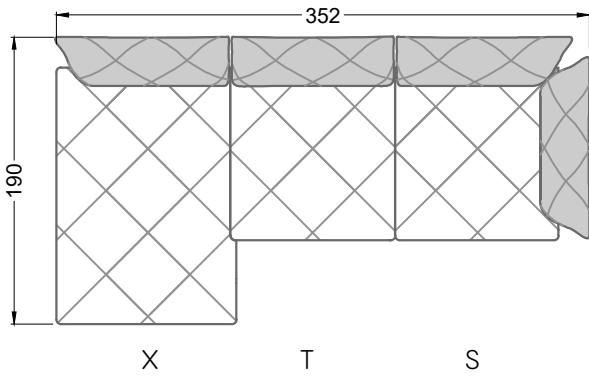
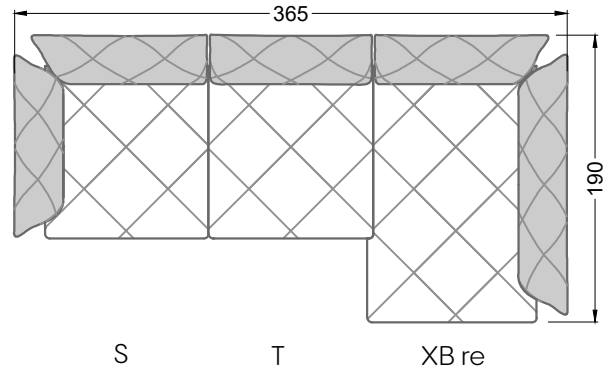
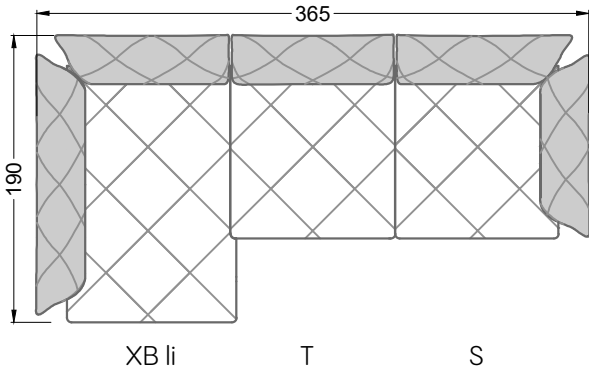
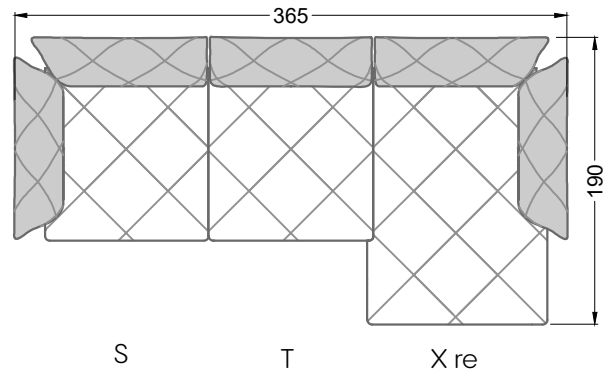
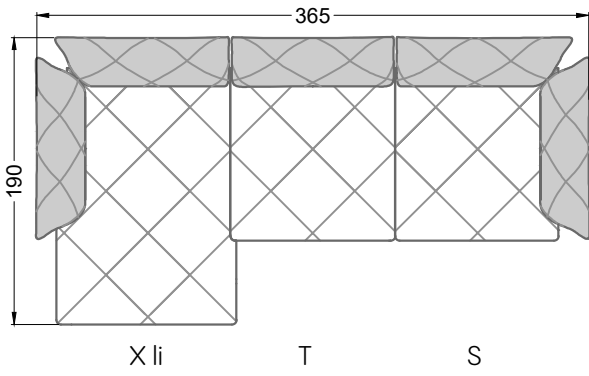

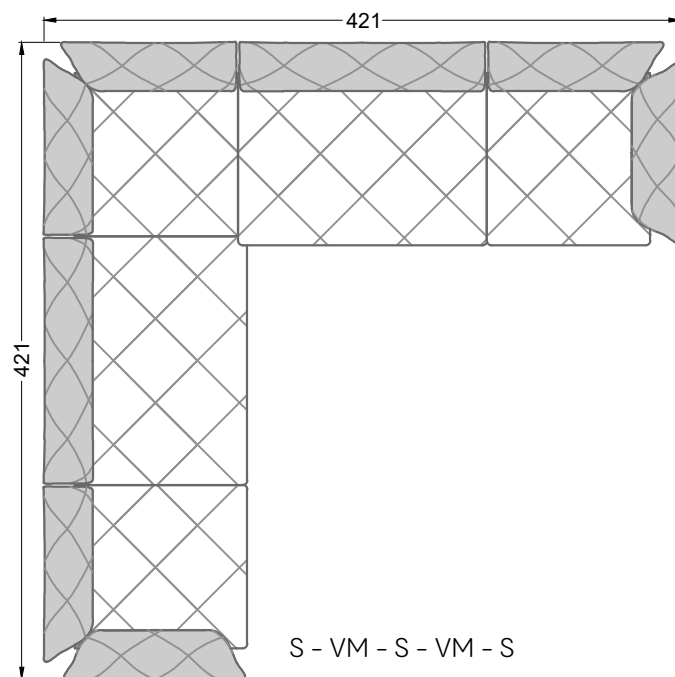
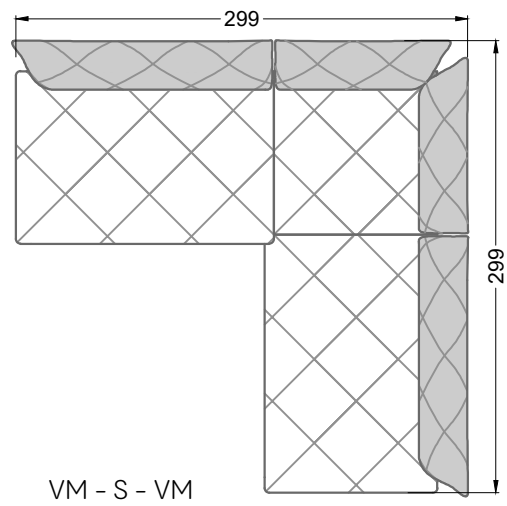
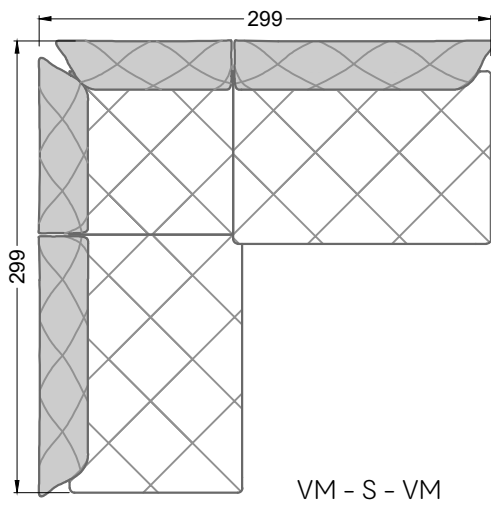
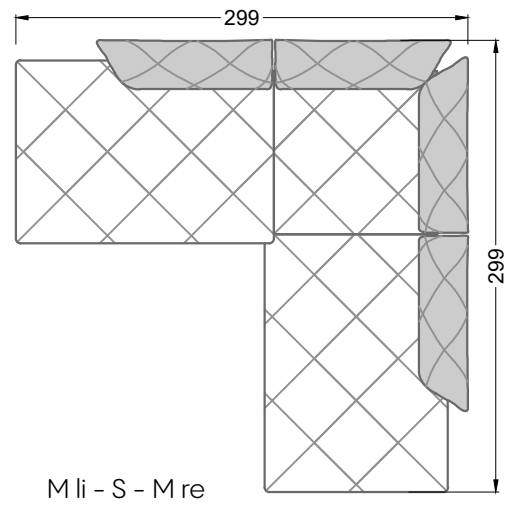
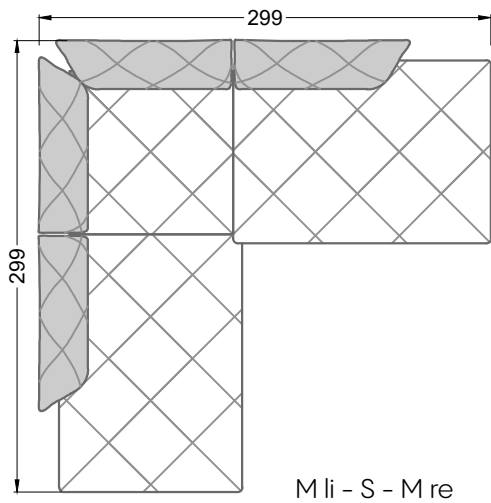

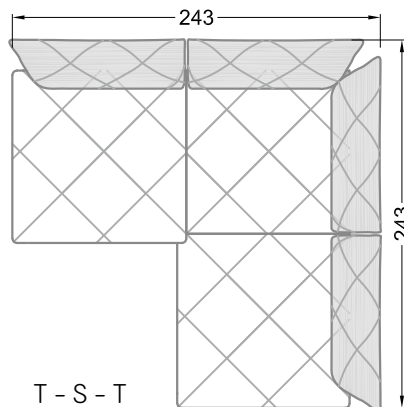
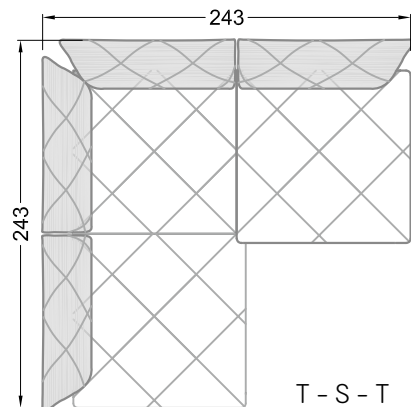
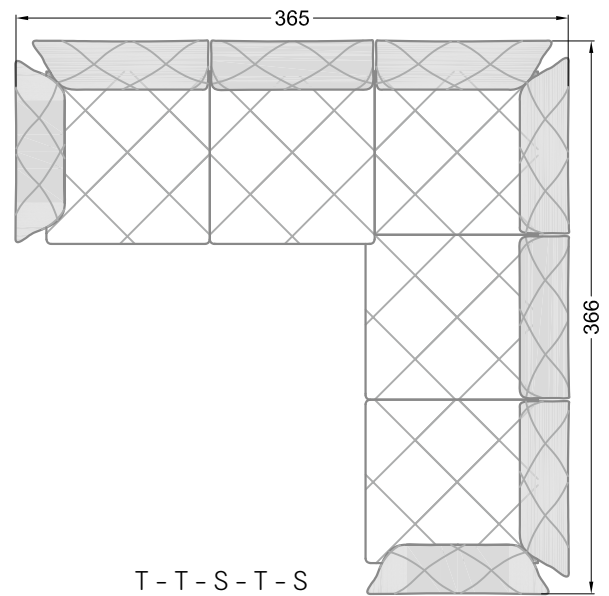
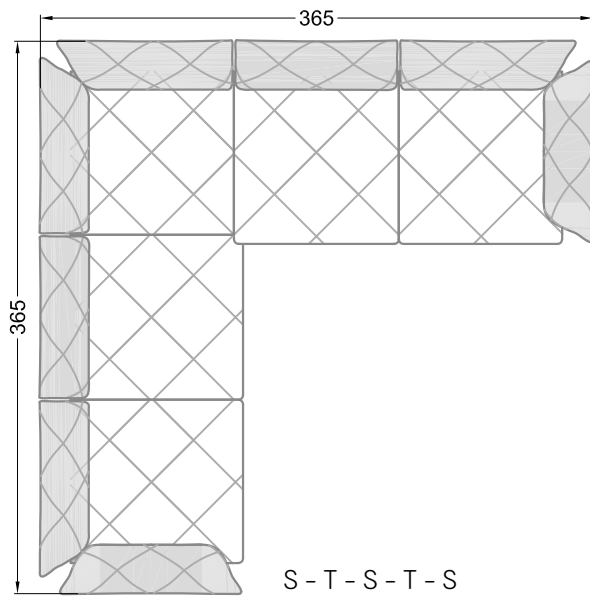
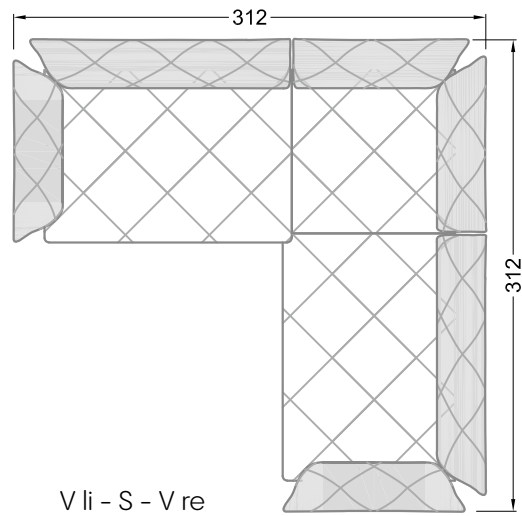
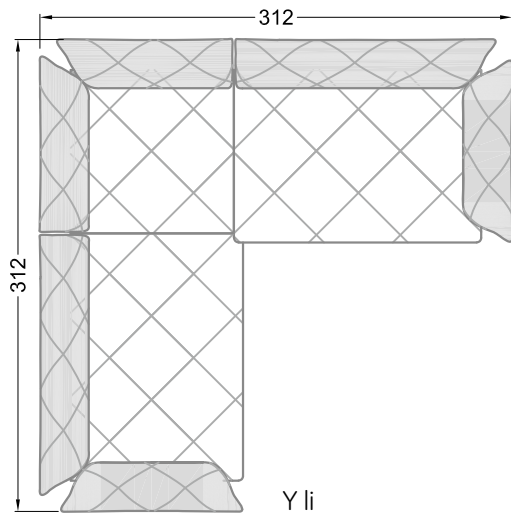

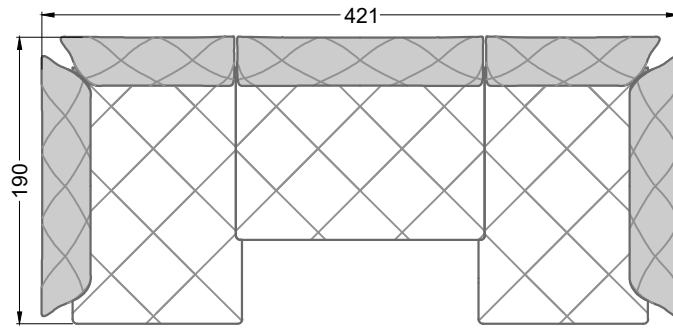

XB li - VM - XB re

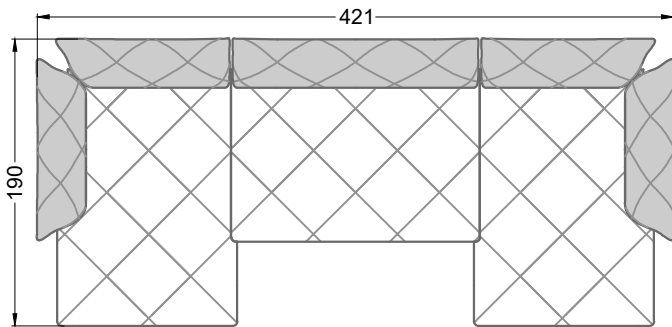

X li - VM - X re

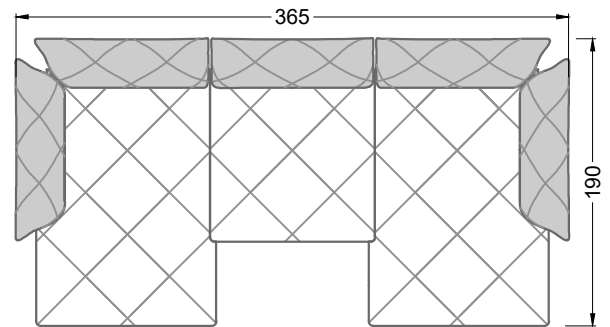

X li - T - X re

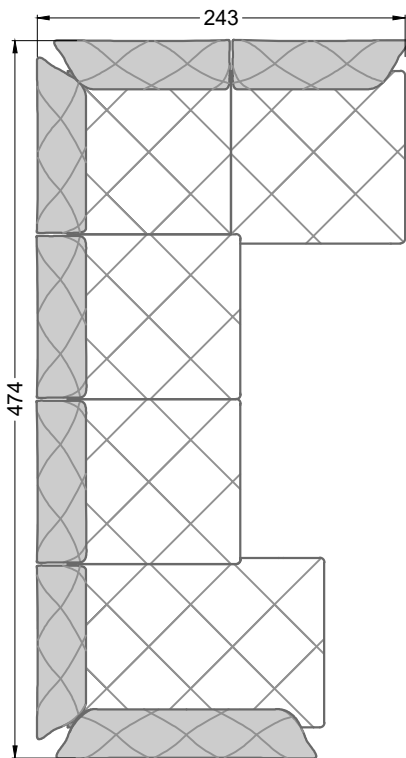

XB li - T - T - S - T

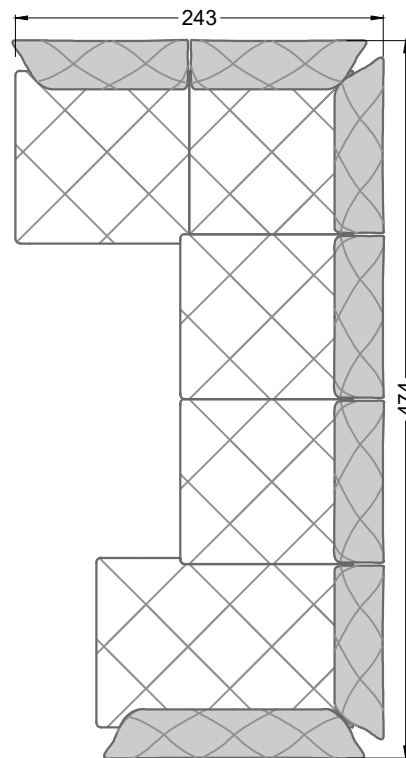

T - S - T - T - XB re

